

Sprint Saw 910203 Operating Manual

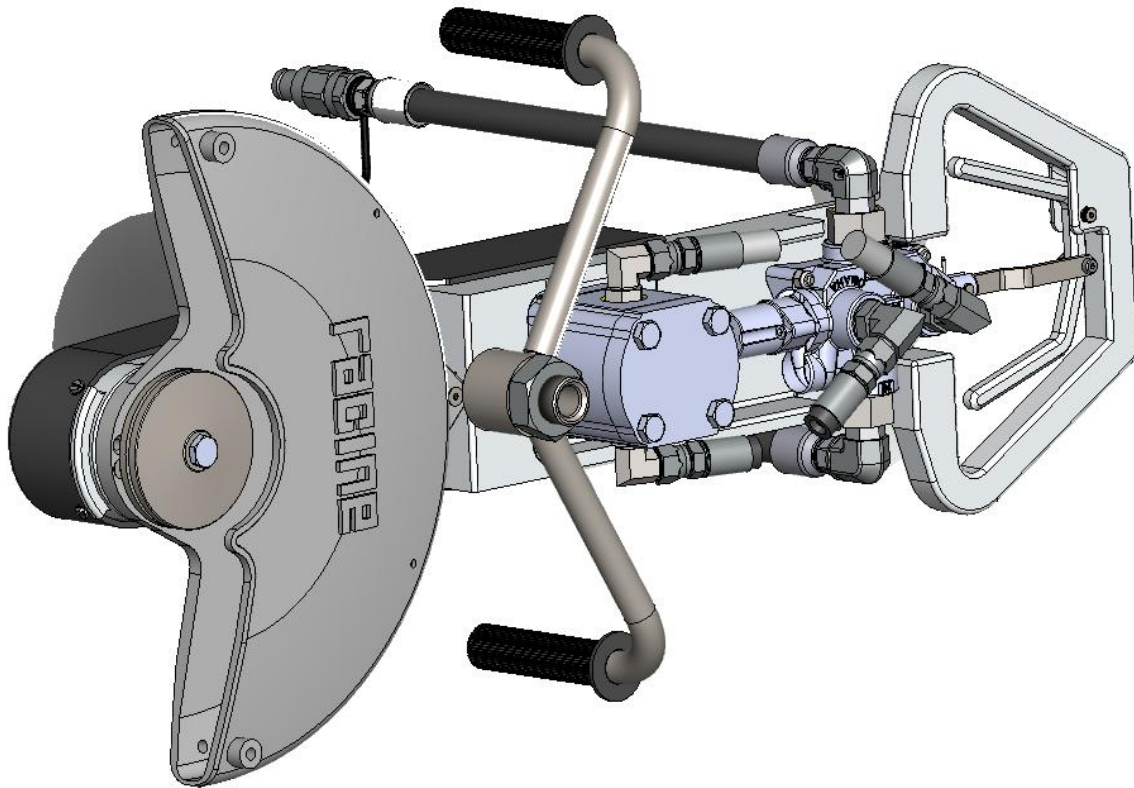

Sprint Saw

910203

Record of Changes

Rev No.	Date	Description of Changes
Rev 1	3.2023	Initial release.
Rev 1.2	10.2023	Update Technical Support & Service information

Table of Contents

Section 1: Overview and Safety	5
Sprint Saw Overview	5
Environmental Protection	5
Safety Information	6
Safety Terms	6
Machine Use and Safety Precautions	6
Section 2: Specifications and Installation.....	7
Specifications	7
Initial Assembly	8
Parts and Controls	8
Setup and Adjustments	9
Hose Requirements	10
Hose Types	10
Hydraulic Hose Recommendation	11
Hydraulic Fluid Recommendation	11
Tool Connecting Procedures	12
Disconnecting Hoses	12
Section 3: Tool Operation	13
Personal Protective Equipment	13
Operating Procedures	13
Cutting the Rail	14
Normal Shut-Down Procedures.....	15
Section 4: Maintenance.....	16
Section 5: Parts and Service Support	17
Sprint Saw / RRP# 910203 [Rev 1 (3.2020)]	18
Clamp, Rail / RRP# 718097 [Rev 1 (7.2017)]	19
Sprint Saw / RRP# 719615 [Rev 1 (3.2020)]	20
Sprint Saw / RRP# 719615 Parts List	22
Section 6: Warranty Terms and Conditions	23

This page was intentionally left blank.

Section 1: Overview and Safety

Sprint Saw Overview

Racine Railroad Products designs and manufactures equipment primarily for the repair and new construction of rail and railroad tie track maintenance.

The Racine Railroad Products Sprint Saw is a portable, hydraulically powered, single blade saw designed for vertical on track rail cutting. The saw has a screw-type rail clamp that accommodates 80 lb. to 141 lb. rail.

Cutting position is set with clamp and ball bearing articulating pivoting arms with an adapting rail clamp and a manual screw with T-handle. The Sprint Saw uses ANSI approved abrasive cutting disc blades.

Do not use this machine for other than its intended purpose.

Please read these instructions when using this tool, which can only be used for the specified purpose. This instruction manual should be kept throughout the life of the tool.

The operator of this tool should:

- Have access to this operation instruction.
- Read and understand this operation instruction.

Note: Information in this document is subject to change without notice.

Environmental Protection



Comply with relevant national waste disposal laws and regulations. Waste electronic devices cannot be treated as household waste.

Equipment, accessories, and packaging shall be recyclable.



Do not throw the discarded equipment in trash cans.

Safety Information

For safe installation and operation of this equipment, carefully read and understand the contents of this manual. Improper operation, handling, or maintenance can result in equipment damage and personal injury.

Only trained and authorized personnel should be allowed to operate this machine. In addition, all personnel at the worksite should be aware of the safety concerns and their individual responsibilities prior to working with this machine.

Please read and comply with all the safety precautions in this manual **before** operating this machine. Your safety is at risk.

Safety Terms



DANGER

DANGER indicates a hazardous operating procedure, practice, or condition. If the hazardous situation is not avoided death or serious injury will occur.



WARNING

WARNING indicates a hazardous operating procedure, practice, or condition. If the hazardous situation is not avoided death or serious injury could occur.



CAUTION

CAUTION indicates a potentially hazardous operating procedure, practice, or condition. If the hazardous situation is not moderate or minor injury could occur.

Machine Use and Safety Precautions



WARNING

Failure to follow safety precautions when operating this equipment can result in serious injury or death to the operator or other persons in the area.

Observe the following precautions whenever you are operating, working on or near this equipment.

Do not use this machine for other than its intended purpose.

Do not make any modifications without authorization or written approval from Racine Railroad Products. Replace all Racine Railroad Products and OEM parts with genuine Racine Railroad Products and OEM parts. Using non-OEM parts may compromise the safety of the machine.

Do not wear loose clothing, jewelry, radio belts, etc., when operating, working on or near this equipment. They can be caught in moving parts and may result in severe injury.

Always wear appropriate personal protective clothing when operating this equipment: e.g., Orange safety vest, hard hat, safety glasses with side shields, hearing protection, steel-toed safety boots, leather gloves, dust respirator, etc.

Always lift heavy objects with the knees and legs, not the arms and back.

Always keep hands, arms, feet, head, clothing, etc., out of the operating area and away from all rotating or moving components when operating, working on or near this machine.

Always make sure that all guards, covers, belts, hoses, and operating components are in good working order and that all controls are in the appropriate position before starting the engine.

Always make sure that all safety equipment installed properly and are in good working order. Do not operate the machine until unsafe conditions have been corrected.

Always operate in a well-ventilated area and make sure that the air filters, air filter covers, and muffler are in good condition.

Always keep the machine clean and free of debris. Operate the machine in a safe and responsible manner. Exercise caution when fueling, working on or near rotating or moving components, hot components, and fuel systems. Be aware of potential fire hazards and prevent sparks, exhaust, etc., from starting fires on the machine and/or work area.

Always comply with all instructions provided on any decals or placards installed on the machine and with any relevant amplifying information provided in this manual or other general operating procedures.

Always shut off or disconnect the power source and make sure that all controls are in a safe position and install all appropriate locking and safety devices before doing any of the following:

- Lubricating
- Adjusting
- Installing Tooling
- Making Repairs
- Performing Service

Section 2: Specifications and Installation

Specifications

Physical Data

Length:..... 40 in. (101 cm)

Width:..... 10 in. (25 cm)

Height, Work Mode: 17 in. (43 cm)

Weight:..... 40 lbs. (16.6 kg)

Mechanical Data

Motor:..... 10 GPM @ 2000 psi (38 LPM @ 138 bar) hydraulic motor

Drive: Pulley and Belt Drive

Performance Data

The Sprint Saw can cut rail from both sides by pivoting the saw on the rail clamp, using most of the cutting wheel.

Cutting Blade Speed:.... 16" (40 cm) diameter wheels are rated for 4800 rpm maximum.

Production Rate: 90 seconds/cut @ 3400 rpm

[16" (40 cm) diameter wheel using Bullard brand blade on 132 lbs rail]

Initial Assembly

The Sprint Saw was tested after assembly at our factory. After assembly, the machine should receive a thorough In-Service inspection before initial operation.

Uncrating

The Sprint Saw is packaged in a corrugated box. Lift the machine clear of the box and place on a safe surface.

Initial Assembly

After unpacking and inspecting the Sprint Saw, prepare it for service by doing the following:

- Check all aspects of the motor, arm, and rail clamp.
- Check the controls for proper operation.
- Install a cutting blade.
- If small boss is installed, replace with Ø1.75 stop boss (311814).

Parts and Controls

Rail Clamp

The over-center rail clamp positions and attaches the Sprint Saw to the rail for precise rail cutting.

There are two ball bearing articulating arms. One attaches to the over center rail clamp while the other attaches to the Sprint Saw to provide ample support.

- A T-handle screw in the rail clamp fixture is used to clamp the rail clamp onto the rail ball.

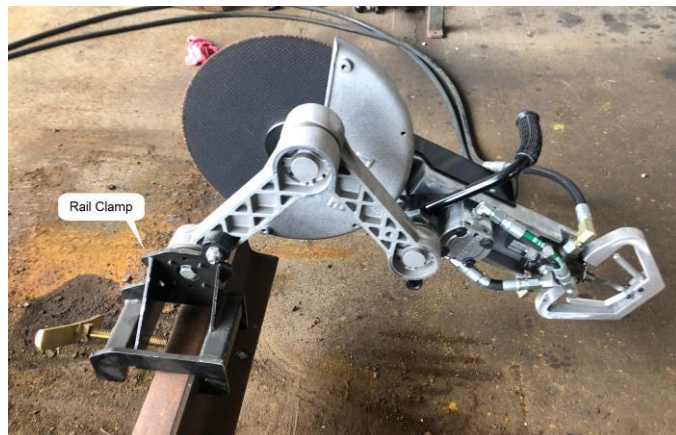

Warning! The T-Handle must be secure to prevent the clamp from moving during cutting use.

Assist Handle

Stand with one hand on the forward assist handle and one on the rear handle adjacent to the trigger



Setup and Adjustments



Rail Clamp with Large Boss

Rail Cutting

The Sprint Saw can be set-up using two methods.



Rail Top Cutting



Rail Side Cutting

Hose Requirements

It is not often necessary or advisable to use long hoses. All hoses must have an oil resistant inner surface and an abrasion resistant outer surface. Each hose must have male pipe ends for most application.

Longer hoses can be used when necessary but can affect the operation of the tool due to resistance in the hose.

If small diameter or long hoses are used, or if restrictive fittings are connected to the supply and return ports, the pressure required to push the fluid through the system and back to the tank will be higher. This will reduce tool power.

Important: Oil should always flow from the male coupler through the female coupler.

Note: The pressure increases in uncoupled hoses left in the sun. This may make them difficult for them to connect. When possible after use, connect the free ends of the operating hoses together.

Hose Types

Hydraulic hose types authorized for use with the tool are:

1. **Labeled and certified non-conductive.**

- This is the only hose authorized for use near electrical conductors.
- Constructed of thermoplastic or synthetic rubber inner tube, synthetic fiber braid reinforcement, and weather resistant thermoplastic or synthetic rubber cover.

2. **Wire braided** (conductive)

- This hose is conductive and must **never** be used near electrical conductors.
- Constructed of synthetic rubber inner tube, single or double wire braid reinforcement, and weather resistant synthetic rubber cover

3. **Fiber braided** (not certified or labeled non-conductive)

- This hose is conductive and must **never** be used near electrical conductors.
- Constructed of thermoplastic or synthetic rubber inner tube, synthetic fiber braid reinforcement, and weather resistant thermoplastic or synthetic rubber cover.

The rated working pressure of the hydraulic hose must be at least 175 bar (2500 psi).

Hydraulic Hose Recommendation

Hydraulic Hose Recommendation								
Flow Per Circuit		Length Each Hose		Use	Inside Diameter		SAE Spec Hose (Wire Braid)	SAE Spec Hose (Fiber Braid)
GPM	LPM	Feet	Meter		Inch	MM		
5 to 8	19 to 30	To 50	To 15	Both	1/2	13	SAE 100R1-8	100R7-8
5 to 8	19 to 30	51 to 100	15 to 30	Both	5/8	16	SAE 100R2-10	SAE 100R8-10
5 to 8	19 to 30	100 to 300	30 to 90	Pressure Return	5/8	16	SAE 100R2-10	SAE 100R8-10
					3/4	19	SAE 100R1-12	SAE 100R7-12
9 to 12	34 to 45	To 50	To 15	Both	5/8	16	SAE 100R2-10	SAE 100R8-10
9 v 12	34 to 45	51 to 100	15 to 30	Pressure Return	5/8	16	SAE 100R2-10	SAE 100R8-10
					3/4	19	SAE 100R3-12	SAE 100R7-12
9 to 12	24 to 45	100 to 200	30 to 60	Pressure Return	3/4	19	SAE 100R2-12	SAE 100R8-12
					1	25.4	SAE 100R1-16	SAE100R7-16

The rated working pressure of the hydraulic hose must be at least 2500 psi / 173 bar.

Hydraulic Fluid Recommendation

Inspect hoses for cuts, crushing, leaks, or abrasion, which may be a safety hazard or reduce fluid flows.

The following fluids work well over a wide temperature range at startup, allow moisture to settle out, and resist biological growth in cool operating hydraulic circuits.

Others that meet or exceeds the specifications of these fluids may also be used.

Type	Hydraulic fluid
Amsoil	AWH ISO 32
Chevron	Rando HD Premium Oil MV ISO VG 32 Rando HDZ ISO 32
Gulf	Harmony AW ISO Multi-Grade 32
Mobil	DTE Oil Excel 32
Schaeffer	Dillex Supreme Hydraulic Fluid w/ Dynavis ISO 46.
Shell	Shell Tellus S2 VX 32
Sunoco	Sunvis 1032 HVI Hydraulic Oil

Tool Connecting Procedures

1. Stop the engine before connecting the tool and or hoses to the power unit, and when switching hoses or tools.
2. Turn the hydraulic on/off valve to the off position before starting the engine.
Make sure all hoses are connected for correct flow direction to and from the tool being used.
When routing hose in the work area, position them where personnel will not be at risk of tripping over them where vehicles can run over the hoses. Do not lay hose over sharp objects.

**WARNING**

Pressurized fluid escaping from a damaged hose can penetrate the skin and be injected in the body causing injury or death.

Do not pull on hoses to drag the power unit or tool.

Connecting Hoses

1. Wipe quick couplers with a clean lint free cloth before connecting them.
2. Depressurize the system.
3. Allow system and hydraulic fluid to cool if too hot to handle.
4. Securely connect the return (tank "R") hose from the power source to the tool.
5. Securely connect the supply (pressure "P") hose from the power source to the tool.

It is recommended that you connect the return hoses first and disconnect last to minimize or avoid trapping pressure within the tool.

When connecting the quick couplers, the flow should run from male coupler to the female coupler. The female coupler on the tool is the inlet. Quick couplers are marked with a flow direction arrow.

**WARNING**

Pressurized fluid escaping from a damaged hose can penetrate the skin and be injected in the body causing injury or death.

Do not pull on hoses to drag the power unit or tool.

Note: When possible, connect the free ends of uncoupled hoses to prevent build up in the hoses. The sun can also increase pressure in the hoses and make connecting them difficult.

Disconnecting Hoses

1. Stop the hydraulic power source.
2. Depressurize the system.
3. Allow system and hydraulic fluid to cool.
4. Disconnect the supply (pressure) hose from the power source (pressure port) from the tool (IN port).
5. Disconnect the return (tank) hose to the hydraulic power source (return port) from the tool (OUT port).
6. To prevent contamination, always install dust caps over the hydraulic ports of the tool when disconnected.

Section 3: Tool Operation

Personal Protective Equipment



Before operating this machine, make sure that all general safety precautions are observed, and that proper personal protective clothing is worn as described below.

At a minimum, operators should wear the following Personal Protective Equipment:

1. Safety Glasses
2. Hearing Protection
3. Hard Hat
4. High Visibility Safety Vest
5. Leather Work Gloves
6. Steel Toed Safety Shoes

Operating Procedures

Daily Inspection

At a minimum, perform the following routine daily maintenance on the Sprint Saw to keep it in good working condition.

- General condition of the machine.
- All guards and safety devices are installed and operable.
- All controls are operable.
- Rail clamp device is operable.

Cutting the Rail

 **CAUTION** Do not operate the saw when bystanders are near the work area.

Note: Depending on temperature, let the power unit and saw warm up before applying full load.

1. Clamp the Sprint Saw on the rail.
2. Make necessary adjustments.
3. Start the engine and advance it to full speed.
4. Start the cutting at the top of rail head by working the blade in an arc swinging motion using the arms and pivot shaft as a vantage factor.
5. Continue cutting through the rail web and rail base.
6. Release the engine throttle once the blade cuts the rail completely.
7. Turn the engine's ignition switch OFF before unclamping and moving the rail saw to the next location.
8. Set the rail saw onto the track rail designated work area and clamp securely.
9. Restart power unit and repeat the operation



Crossing Over the Saw

1. Stop cutting the rail before crossing over the Sprint Saw.
2. Use the Assist Handle and move the saw over.
3. Position yourself onto the opposite side of the rail.
4. Return to normal operation.



Do not grab the rail saw frame trigger during the crossover procedure.



Crossing over the Saw

Normal Shut-Down Procedures

Safely transport and store the Sprint Saw.

1. Release the trigger and allow the wheel to stop moving.
2. Shut down the hydraulic power unit.
3. Disconnect the hydraulic hoses.
4. Disengage the rail clamp.
5. Prepare the unit for transport.

Emergency Procedures

In the event of any malfunction, **immediately shut-off the power unit and correct the problem.**



Do not perform maintenance on the Sprint Saw while the power unit is running.

Section 4: Maintenance

It is highly recommended to practice regular check-ups and maintenance in accordance with the usage frequency to keep your tool in better condition and reduces total running costs.

Maintenance of the Sprint Saw can be performed without any special maintenance related safety devices. Before operating the Sprint Saw, perform a daily inspection of the machine.

Make sure all general safety precautions are observed and that proper personal protective clothing is worn.

Safety Devices

Make sure the following safety devices are installed on the machine after maintenance:

- Hydraulic Hoses are properly installed.
- Rail Clamp is secure.

Grease Type and Locations

Permanently sealed bearing and self-lubricating bushings are used extensively on the Sprint Saw to reduce daily maintenance.

Section 5: Parts and Service Support

Technical Support & Service

Telephone and web-based technical support is available for current production models through our Customer Service Department. Service Manuals and limited technical support may be available for models that are no longer in production.

Telephone and E-mail Technical Support

Telephone and e-mail technical support is available on normal U.S. business days from 8:00 AM to 5:00 PM U.S. Central Time Zone (GMT +6 (+5 Daylight Savings Time)).



1955 Norwood Court
Mount Pleasant, WI 53403
Phone: (262) 637-9681
Email: custserv@racinerailroad.com
racinerailroad.com



Unit 3 Hartington Industrial Estate
Chesterfield • Derbyshire, S43 3YF
Phone: 0330 164 1375
Email: info@racinerailroad.co.uk
racinerailroad.co.uk

Non-Warranty Technical Support

Depending upon the circumstances and availability of technical service personnel, we may provide technical assistance and/or field service support, *at the customer's expense*, to assist in the correction of non-warranty related problems. Contact our Customer Service Department to coordinate Non-Warranty Technical or Field Service Support.

Warranty Support Technical Support

Depending upon the circumstances and availability of technical service personnel, we may provide technical assistance and/or field service support, *at no charge to the customer*, to assist in the correction of warranty related problems. Contact our Customer Service Department to coordinate Warranty Technical or Field Service Support.

Warranty Parts Claims

Material claimed to be defective must be returned to our factory for evaluation. Defective materials will be replaced, or your account will be credited if replacement materials have already been purchased. Please contact our Customer Service Department at the address provided below if you have any questions or problems.

Warranty Service Support

Depending upon the circumstances and availability of technical service personnel, we may provide technical assistance and/or field service support, at no charge to the customer, to assist in the correction of warranty related problems. Contact our Customer Service Department at the address provided above to coordinate Warranty Service Support.

Sprint Saw / RRP# 910203 [Rev 1 (3.2020)]

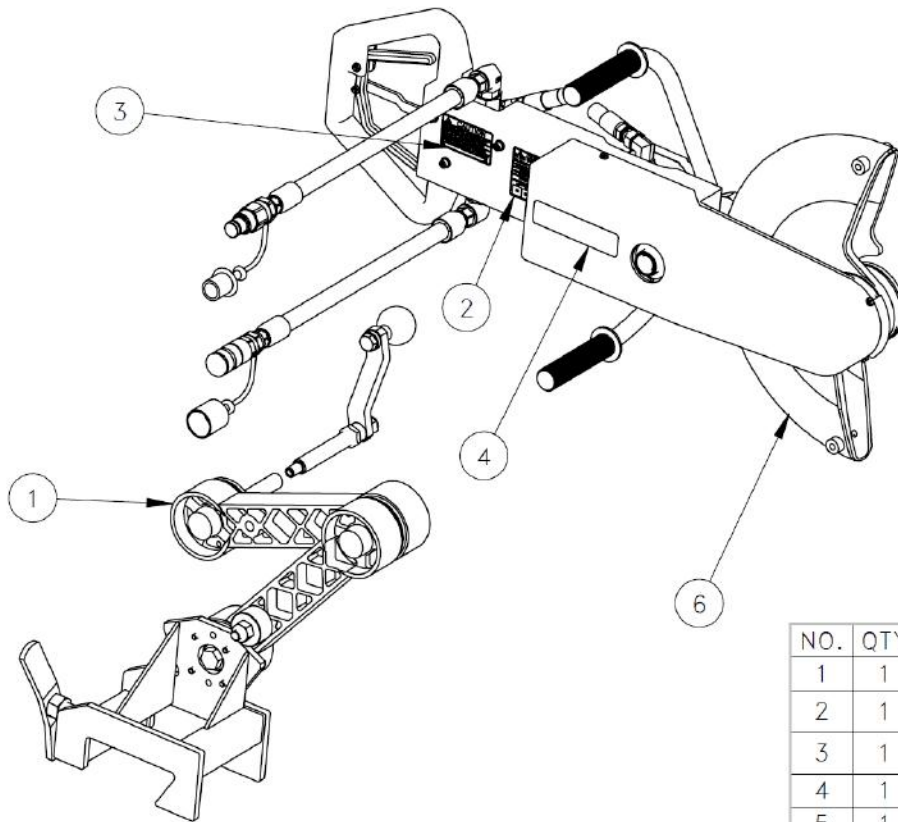

NO.	QTY	DESCRIPTION	PART NO.
1	1	CLAMP, RAIL	718097
2	1	DECAL, CAUTION: 10 GPM/2000 PSI	465474
3	1	DECAL, CAUTION: WHEEL REPLACEMENT	465450
4	1	DECAL, SPRINTSAW	466775
5	1	MANUAL, SPRINTSAW	910203-M
6	1	SPRINTSAW	719615

Clamp, Rail / RRP# 718097 [Rev 1 (7.2017)]

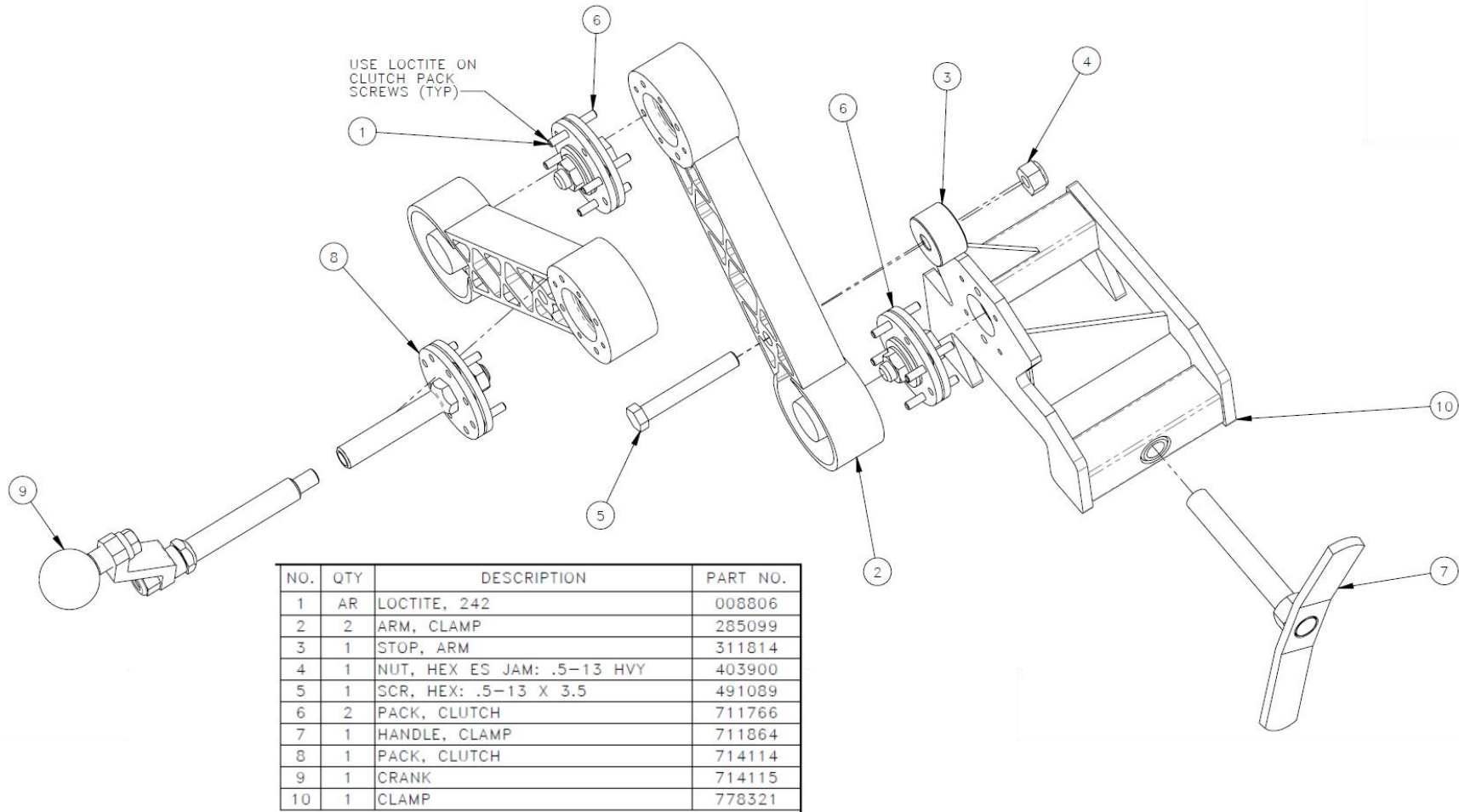

Sprint Saw / RRP# 719615 [Rev 1 (3.2020)]

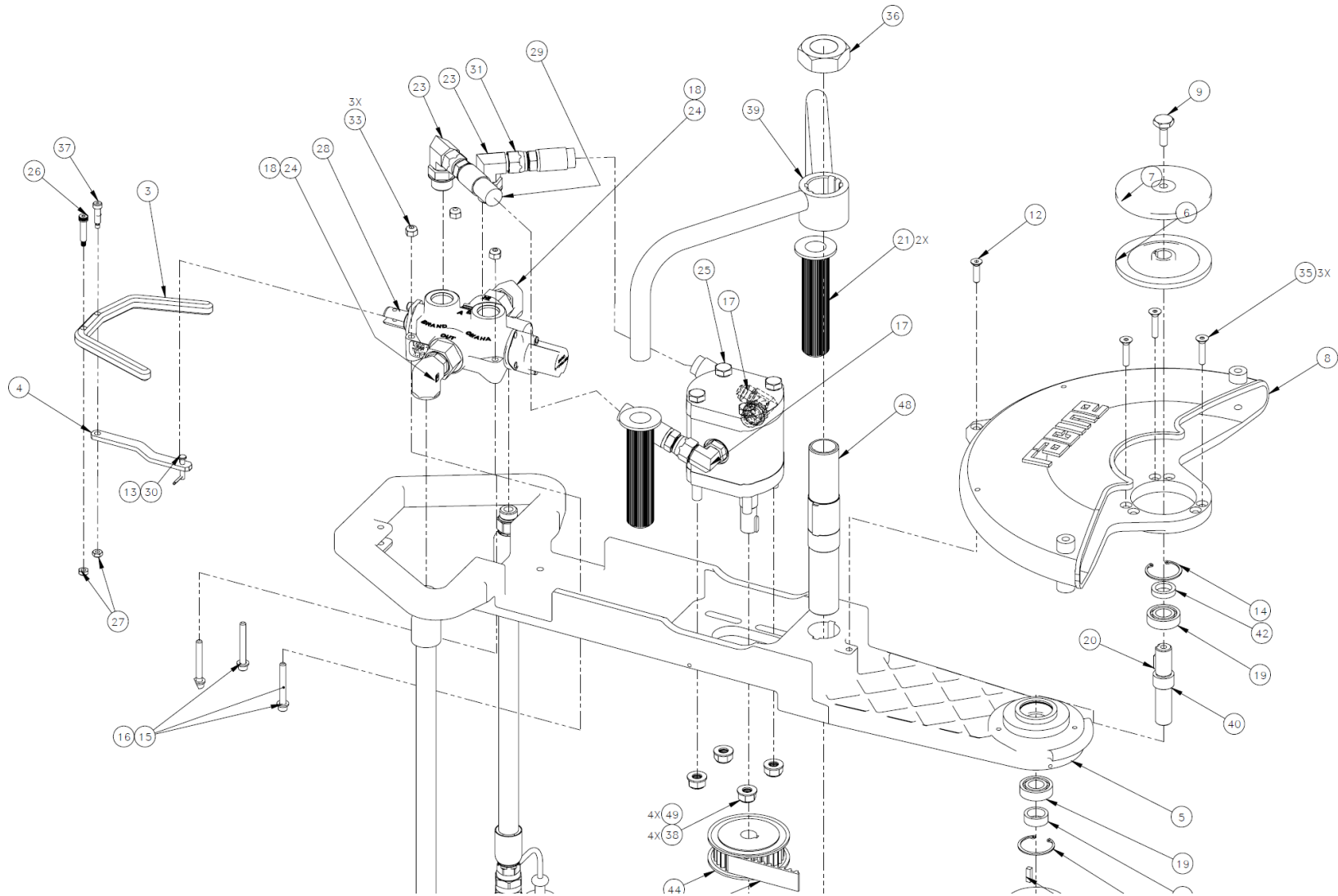

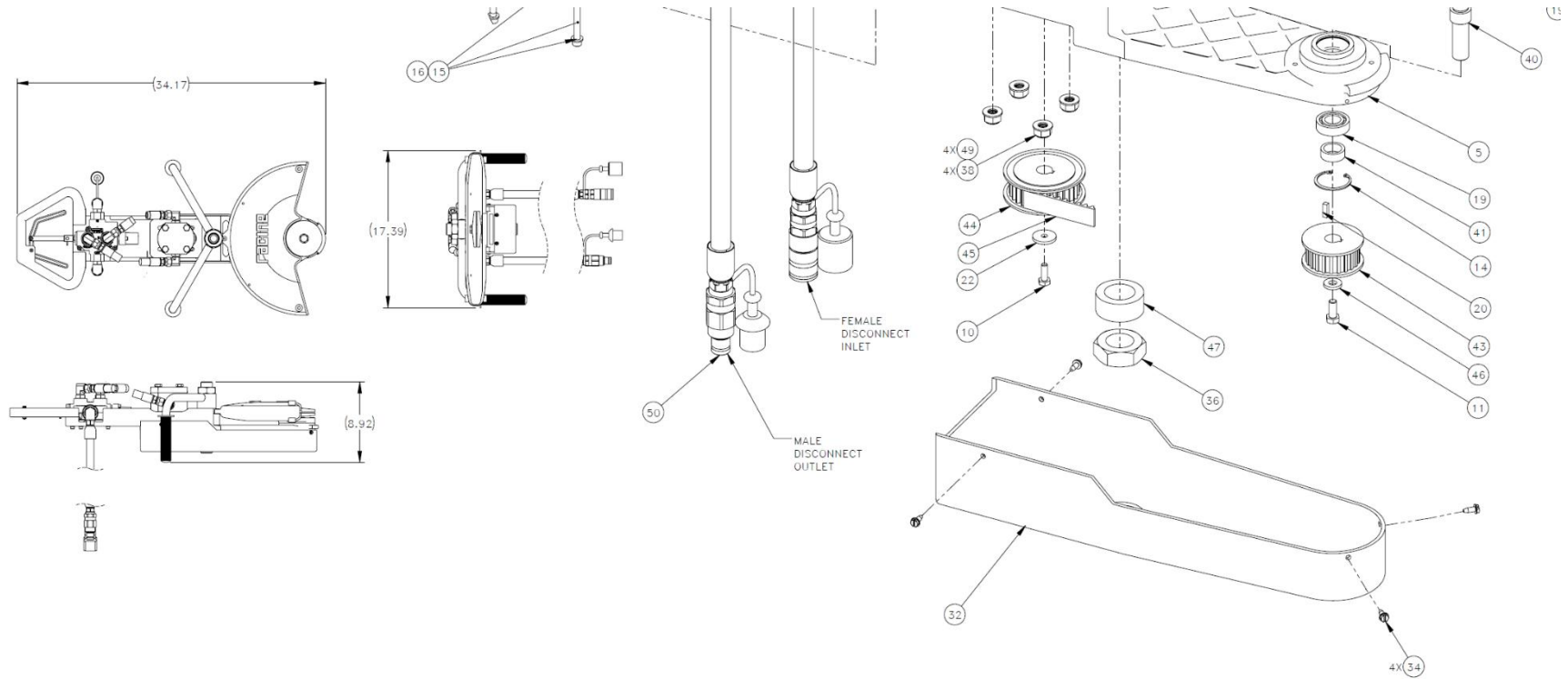

Sprint Saw / RRP# 719615 Parts List

NO.	QTY	DESCRIPTION	PART NO.
1	AR	LOCTITE, 242	008806
2	AR	LOCTITE, PRIMER T	008825
3	1	TRIGGER	320446
4	1	STEM, TRIGER	320447
5	1	FRAME, RAILSAW	321211
6	1	FLANGE, KEYED	390649
7	1	FLANGE, KEYED	390650
8	1	GUARD	390773
9	1	SCREW	391328
10	1	SCR, HEX: .25-20 X .75	400684
11	1	SCR, HEX: .31-18 X .75	400696
12	1	SCR, SOC FLT: .25-20 X 1	400847
13	1	PIN, COTTER: .09 X .5	400895
14	2	RING, RETAINING: 1.378 DIA INT	401238
15	3	SCR, SOC: .25-20 X 2	407650
16	3	WASHER, FLT: .25	408686
17	2	ELBOW, 90°: #8 JIC(M) X #8 SAE(M)	459813
18	2	REDUCER, #12 SAE(M) X #8 SAE(F)	459881
19	2	BRG, BALL: .67 ID	461780
20	2	KEY, SQ: .19 X .62	462192
21	2	GRIP	462263
22	1	WASHER, FLT: .26	462369
23	2	ELBOW, 90°: #8 JIC(M) X #10 SAE(M)	464886
24	2	ELBOW, 90°: #8 SAE(M) X #8 SAE(F)	466562
25	1	MOTOR, HYDR: .89 CIR	471057
26	1	SCR, SOC SHLD: .25 X 1	471063
27	2	NUT, HEX ES: 10-32 THIN	474593
28	1	VALVE, CONTROL	474596
29	1	HOSE ASSY, #8 X 9 CR	474604
30	1	PIN, CLEVIS: .19 X 1	474636
31	1	HOSE ASSY, #8 X 7 CR	474659
32	1	GUARD, BELT	475097
33	3	NUT, HEX ES: .25-20	491232
34	4	SCR, SEL TPG: 10-24 X .5	491315
35	3	SCR, SOC FLT: .25-20 X 1.25	491561
36	2	NUT, HEX JAM: 1.25-12	491805
37	1	SCR, SOC SHLD: .25 X .75	491872
38	4	NUT, HEX ES: M10-1.5	501081
39	1	HANDLE	780532

NO.	QTY	DESCRIPTION	PART NO.
40	1	SHAFT, BLADE	10000196
41	1	BUSHING, BELT SIDE LOWER	10000205
42	1	SPACER, BLADE SIDE	10000206
43	1	SPROCKET, 8 MM 22 TOOTH	10000238
44	1	SPROCKET, 8 MM 30 TOOTH	10000239
45	1	BELT, DRIVE	10000251
46	1	WASHER, FLT: .31	10000293
47	1	SPACER, SUPPORT TUBE	10000412
48	1	TUBE, SUPPORT	10000424
49	4	WASHER, FLT: M12	25005103
50	1	HOSES, WHIP	26002503

Section 6: Warranty Terms and Conditions

Warranty Period

Each new machine and new parts of our manufacture are warranted against defects in material and workmanship for one year from the date of shipment from our factory.

When contacting customer service for factory parts, service or warranty support please provide the:

- Racine Railroad Products Model
- Serial Number
- Any locally assigned identification

Vendor Parts Warranty Period

Other equipment and parts used, but not manufactured by Racine Railroad Products, Inc., are covered directly by the manufacturer's warranty for their products.

Warranty Parts and Service

We will repair or replace, without charge, F.O.B. factory, Racine, Wisconsin, USA, any part Racine Railroad Products manufactures which is proven to be defective during the warranty period.

Material claimed defective must be returned, if requested, to the factory within 30 days from the date of the claim for replacement. Ordinary wear and tear, abuse, misuse, and neglect are not covered by this warranty. Depending upon the circumstances, we may provide technical assistance and/or technical service support, without charge, to assist in the correction of warranty related problems.

Non-Warranty Parts and Service

Material damaged through normal wear and tear, abuse, misuse and/or neglect are not covered by our warranty and should be ordered directly from Customer Service.

Note: Parts for models that are no longer in production may not be available.

Non-Warranty Parts Orders

When placing a parts order please provide the following information:

- Company Name and Billing Address
- Purchase Order Number and Issuing Authority
- Shipping Address
- Special Handling Instructions
- Contact Phone Number
- Machine Model and Serial Number
- Part Numbers and Quantities Being Ordered

Note: Please use Racine Railroad Products part numbers when ordering parts. Racine Railroad Products part numbers are shown in the parts lists and drawings of this manual and have only six (6) numbers.

Any part number with other than six numbers (e.g., contains alpha-numeric characters) is a Vendor Part Number and **not** a Racine Railroad Products part number